

Types 95L, 95H, 95HP and 95HT Pressure Reducing Regulators

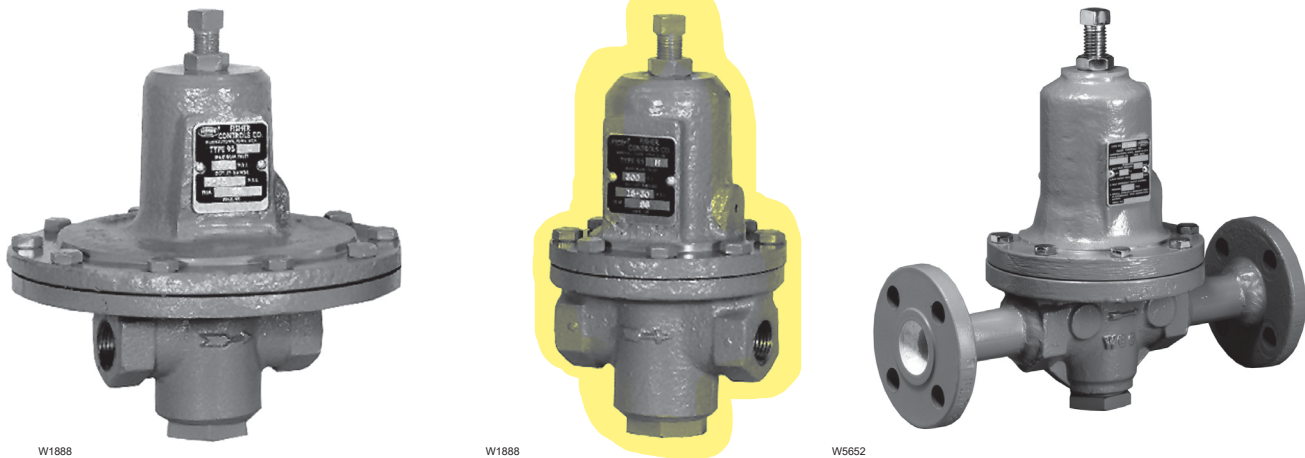

Figure 1. Type 95L NPT Body (Left), Type 95H NPT Body (Middle), and Type 95H Flanged Body (Right) Pressure Reducing Regulators



WARNING

Failure to follow these instructions or to properly install and maintain this equipment could result in an explosion, fire and/or chemical contamination causing property damage and personal injury or death.

Fisher™ regulators must be installed, operated and maintained in accordance with federal, state and local codes, rules and regulations and Emerson Process Management Regulator Technologies, Inc. instructions.

If the regulator vents gas or a leak develops in the system, service to the unit may be required. Failure to correct trouble could result in a hazardous condition.

Call a gas service person to service the unit. Only a qualified person must install or service the regulator.

Introduction

Types 95L, 95H, 95HP and 95HT direct-operated pressure regulators are suitable for pressure control of steam, air, gas, water, oil and similar fluids requiring constant outlet pressures between 2 and 400 psig / 0.14 and 27.6 bar. Typical 95L and 95H regulators are shown in Figure 1.

Description

Type 95L—Pressure reducing regulator suitable for controlling many gases and liquids. Cast iron, steel or stainless steel bodies are available. Outlet pressure range is from 2 to 30 psig / 0.14 and 2.1 bar with three

Types 95L, 95H, 95HP and 95HT

Specifications

This section lists the specifications for the Types 95L, 95H, 95HP and 95HT regulators. Factory specification are stamped on the nameplate fastened on the regulator at the factory.

Available Configurations

Type 95L: Low-pressure regulator for 2 to 30 psig / 0.14 to 2.1 bar outlet pressures

Type 95H: High-pressure regulator for 5 to 150 psig / 0.34 to 10.3 bar outlet pressures

Type 95HP: High-pressure regulator for 15 to 400 psig / 1.0 to 27.6 bar outlet pressures (soft-seated)

Type 95HT: High-pressure/high temperature regulator for 15 to 300 psig / 1.0 to 20.7 bar outlet pressures (metal seat) and up to 650°F / 343°C

Body and Orifice Sizes

NPS 1/4 body: 1/4 in. / 6.4 mm orifice

NPS 1/2 / DN 15 body: 3/8 in. / 9.5 mm orifice

NPS 3/4 and 1 / DN 20 and 25 bodies: 9/16 in. / 14 mm orifice

NPS 1-1/2 and 2 / DN 40 and 50 bodies: 1-1/16 in. / 27 mm orifice

End Connection Styles

NPT, ASME flanged; all sizes are fabricated with slip-on flanges and are 14 in. face-to-face (EN flanged-356 mm face-to-face), CL150 RF, CL300 RF, PN 16/25/40 or SWE

Outlet Pressure Range

See Table 1

Maximum Cold Working Pressures of Body Size and Material

See Table 2

Maximum Temperature Ranges of Diaphragm and Seat Materials⁽¹⁾⁽²⁾

MATERIAL	TEMPERATURE RANGE	
	°F	°C
Nitrile (NBR)	-40 to 180	-40 to 82
Neoprene (CR)	-40 to 180	-40 to 82
Fluorocarbon (FKM) ⁽³⁾	0 to 300	-18 to 149
Ethylene propylene (EPDM)	-40 to 275	-40 to 135
Perfluoroelastomer (FFKM)	0 to 425	-18 to 218
Polytetrafluoroethylene (PTFE)	-40 to 400	-40 to 204
Stainless Steel	-40 to 650	-40 to 343

Maximum Temperature Ranges of Body Materials⁽¹⁾⁽²⁾

REGULATOR	BODY AND SPRING CASE MATERIAL	TEMPERATURE RANGE	
		°F	°C
Type 95L Type 95H	Cast Iron	-40 to 406	-40 to 208
	Steel	-20 to 450	-29 to 232
Type 95HP	Stainless Steel	-40 to 450	-40 to 232
	Steel	-20 to 450	-29 to 232
Type 95HT	Stainless Steel	-40 to 450	-40 to 232
	Steel	-20 to 650	-29 to 343
	Stainless Steel	-40 to 550	-40 to 288

Pressure Setting Adjustment

Adjusting screw (standard), Handwheel/Tee handle (optional): NPS 1/2 / DN 15 body has a handwheel, all other sizes have tee handles

Pressure Registration

Internal

Shutoff Classification Per ANSI/FCI 70-3-2004

Metal Seats: Class IV

Elastomer Seats: Class VI or better

PTFE: Class IV

Approximate Weights

Types 95H, 95HP and 95HT:

NPS 1/4 body: 4 lbs / 2 kg

NPS 1/2 / DN 15 body: 8 lbs / 4 kg

NPS 3/4 and 1 / DN 20 and 25 bodies:

20 lbs / 9 kg

NPS 1-1/2 and 2 / DN 40 and 50 bodies:

73 lbs / 33 kg

Type 95L:

NPS 1/4 body: 6 lbs / 3 kg

NPS 1/2 / DN 15 body: 12 lbs / 5 kg

NPS 3/4 and 1 / DN 20 and 25 bodies: 32 lbs / 15 kg

1. The pressure/temperature limits in this Instruction Manual, and any applicable standard or code limitation should not be exceeded.

2. Pressures and/or the body end connection may decrease these maximum temperatures.

3. Fluorocarbon (FKM) is limited to 200°F / 93°C hot water.

Types 95L, 95H, 95HP and 95HT

Table 1. Outlet Pressure Ranges

TYPE	BODY SIZE, NPS / DN	OUTLET PRESSURE RANGE		SPRING WIRE DIAMETER		SPRING FREE LENGTH		COLOR
		psig	bar	In.	mm	In.	mm	
95L	1/4	2 to 6	0.14 to 0.41	0.148	3.76	2.00	50.8	Yellow
		5 to 15	0.34 to 1.0	0.172	4.37	2.00	50.8	Green
		13 to 30	0.90 to 2.1	0.207	5.26	1.93	49.2	Red
	1/2 / 15	2 to 6	0.14 to 0.41	0.207	5.26	2.50	63.5	Yellow
		5 to 15	0.34 to 1.0	0.234	5.94	2.57	65.2	Green
		13 to 30	0.90 to 2.1	0.281	7.14	2.44	62.0	Red
3/4, 1 / 20, 25	2 to 6	0.14 to 0.41	0.306	7.77	4.00	102	Yellow	
	5 to 15	0.34 to 1.0	0.343	8.71	4.00	102	Green	
	13 to 30	0.90 to 2.1	0.406	10.3	4.00	102	Red	
95H	1/4	15 to 30	1.0 to 2.1	0.148	3.76	2.00	50.8	Yellow
		25 to 75	1.7 to 5.2	0.172	4.37	2.00	50.8	Green
		70 to 150	4.8 to 10.3	0.207	5.26	1.93	49.2	Red
	1/2 / 15	15 to 30	1.0 to 2.1	0.207	5.26	2.50	63.5	Yellow
		25 to 75	1.7 to 5.2	0.234	5.94	2.57	65.2	Green
		70 to 150	4.8 to 10.3	0.281	7.14	2.44	62.0	Red
	3/4, 1 / 20, 25	15 to 30	1.0 to 2.1	0.306	7.77	4.00	102	Yellow
		25 to 75	1.7 to 5.1	0.343	8.71	4.00	102	Green
		70 to 150	4.8 to 10.3	0.406	10.3	4.00	102	Red
	1-1/2, 2 / 40, 50	5 to 80	0.34 to 5.5	0.531	13.5	6.56	167	Light Blue
		60 to 120	4.1 to 8.3	0.562	14.3	6.56	167	Light Gray
		100 to 140	6.9 to 9.7	0.593	15.1	6.50	165	Yellow
120 to 150		8.3 to 10.3	0.656	16.7	6.56	167	Black	
95HT	1/4	15 to 100	1.0 to 6.9	0.192	4.88	1.96	49.8	Unpainted
		80 to 300	5.5 to 20.7	0.282	7.16	1.96	49.8	Unpainted
	1/2 / 15	15 to 100	1.0 to 6.9	0.282	7.16	2.50	63.5	Unpainted
		80 to 300	5.5 to 20.7	0.375	9.52	2.50	63.5	Unpainted
	3/4, 1 / 20, 25	15 to 100	1.0 to 6.9	0.437	11.1	4.03	102	Unpainted
		80 to 300	5.5 to 20.7	0.562	14.3	4.03	102	Unpainted
	1-1/2, 2 / 40, 50	15 to 100	1.0 to 6.9	0.625	15.9	6.70	170	Unpainted
		60 to 260	4.1 to 17.9	0.812	20.6	6.70	170	Unpainted
95HP	1/4	15 to 100	1.0 to 6.9	0.192	4.88	1.96	49.8	Unpainted
		80 to 400	5.5 to 27.6	0.282	7.16	1.96	49.8	Unpainted
	1/2 / 15	15 to 100	1.0 to 6.9	0.282	7.16	2.50	63.5	Unpainted
		80 to 400	5.5 to 27.6	0.375	9.52	2.50	63.5	Unpainted
	3/4, 1 / 20, 25	15 to 100	1.0 to 6.9	0.437	11.1	4.03	102	Unpainted
		80 to 400	5.5 to 27.6	0.562	14.3	4.03	102	Unpainted
	1-1/2, 2 / 40, 50	15 to 100	1.0 to 6.9	0.625	15.9	6.70	170	Unpainted
		60 to 300	4.1 to 20.7	0.812	20.6	6.70	170	Unpainted

Table 2. Maximum Cold Working Pressures of Body Size and Material⁽¹⁾⁽²⁾

REGULATOR	BODY SIZE, NPS	BODY AND SPRING CASE MATERIAL	MAXIMUM INLET PRESSURE, psig / bar	MAXIMUM OUTLET PRESSURE, psig / bar
Type 95L	All Sizes	Cast Iron	250 / 17.2	50 / 3.4
		Steel	300 / 20.7	125 / 8.6
		Stainless Steel	300 / 20.7	125 / 8.6
Type 95H	All Sizes	Cast Iron	250 / 17.2	250 / 17.2
		Steel	300 / 20.7	300 / 20.7
		Stainless Steel	300 / 20.7	300 / 20.7
Type 95HP	All Sizes	Steel	600 / 41.4	600 / 41.4
		Stainless Steel	600 / 41.4	550 / 37.9
Type 95HT	1/4 to 1 / DN 25	Steel	600 / 41.4	600 / 41.4
		Stainless Steel	600 / 41.4	550 / 37.9
	1-1/2, 2 / DN 40, 50	Steel	600 / 41.4	450 / 31.0
		Stainless Steel	600 / 41.4	450 / 31.0

1. The pressure limits in this Instruction Manual, and any applicable standard or code limitation should not be exceeded.

2. Temperature and/or the body end connection may decrease these maximum pressures.

Table 3. Torque Specifications

BODY SIZE, NPS / DN	SPRING CASE BOLT ⁽¹⁾	ORIFICE	PLUG GUIDE
	Ft-Lbs / N·m		
1/4	6 to 8 / 8.1 to 11	8 to 12 / 11 to 16	42 to 58 / 57 to 79
1/2 / 15	10 to 13 / 13 to 18	29 to 35 / 39 to 47	70 to 90 / 95 to 122
3/4, 1 / 20, 25	24 to 30 / 33 to 41	33 to 42 / 45 to 57	130 to 160 / 176 to 217
1-1/2, 2 / 40, 50	40 to 50 / 54 to 68	140 to 170 / 190 to 230	170 to 200 / 230 to 271

1. Reduce spring case bolt's torque by 30% when using Ethylenepropylene (EPDM) diaphragms.

Types 95L, 95H, 95HP and 95HT

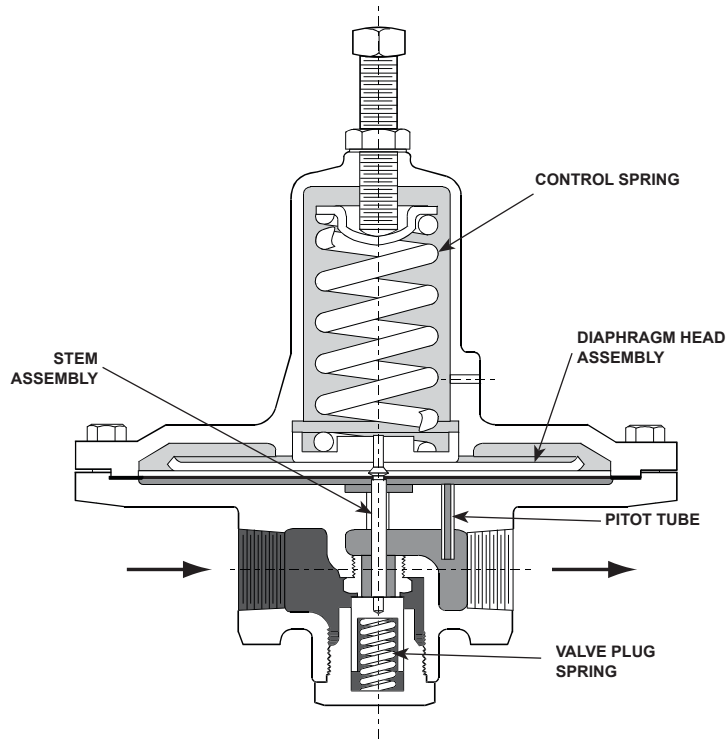

A6554

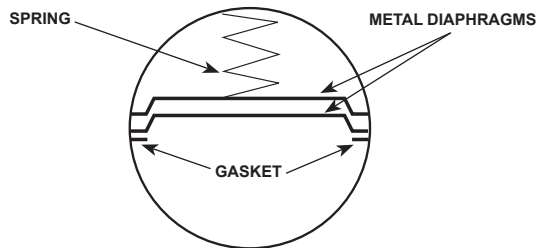

TYPE 95L WITH 2 METAL DIAPHRAGMS
(ALSO TYPICAL OF TYPE 95H OR 95HT, EXCEPT
ONLY TYPE 95L, NPS 1/4, 2 TO 6 psi / 0.14 to 0.41 bar RANGE)

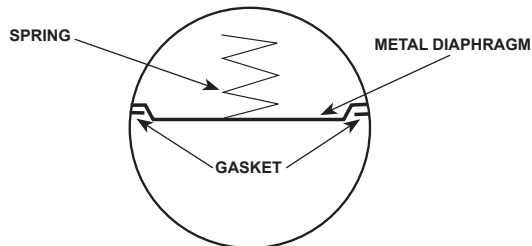

TYPE 95L (NPS 1/4, 2 TO 6 psi / 0.14 to 0.41 bar RANGE)
WITH METAL DIAPHRAGM

Figure 2. Type 95L with Metal Seat and Diaphragm Operational Schematic (Also Typical of Type 95H or 95HT)

different springs available. Body sizes are available from NPS 1/4 through 1 / DN 25 with a variety of end connections. The standard orifice sizes are 1/4, 3/8 and 9/16 in. / 6.4, 9.5 and 14 mm diameter, dependent on body sizes.

Type 95H—Basically the same as Type 95L, but permits higher outlet pressure ranges from 15 to 150 psig / 1.0 to 10.3 bar for the NPS 1/4, 1/2, 3/4 and 1 / DN 15, 20 and 25 sizes. Also available in NPS 1-1/2 and 2 sizes with a 1-1/16 in. / 27 mm orifice to give outlet pressure ranges from 5 to 150 psig / 0.34 to 10.3 bar.

Type 95HP—Basically the same as Type 95H, but permits even higher outlet pressure ranges from 15 to 400 psig / 1.0 to 27.6 bar.

Type 95HT—Basically the same as Type 95H, but permits higher outlet pressures at higher temperatures. Outlet pressure ranges are available from 15 to 300 psig / 1.0 to 20.7 bar and temperatures up to 650°F / 343°C.

Principle of Operation

The 95 Series (refer to Figure 2) is a direct-operated regulator. Downstream pressure is registered internally through the body to the under side of the diaphragm. When the downstream pressure is at or above the set pressure, the disk is held against the orifice, and there is no flow through the regulator. When demand increases, downstream pressure drops slightly allowing the spring to extend, moving the stem down and the disk away from the orifice. This allows flow through the body to the downstream system. Types 95H, 95L, 95HP and 95HT use spring force to regulate outlet pressure.

Installation

Clean out all pipelines before installation of the regulator and check to be sure the regulator has not been damaged or collected foreign material during shipping. Apply pipe compound to the external pipe threads and install the regulator in any position desired, but be sure flow through the body is in the direction indicated by the arrow cast on the body.

Note

It is important that the regulator be installed so that the vent hole in the spring case is unobstructed at all times. For outdoor installations, the regulator

should be located away from vehicular traffic and positioned so that water, ice and other foreign materials cannot enter the spring case through the vent. Avoid placing the regulator beneath eaves or downspouts, and be sure it is above the probable snow level.

On NPS 1-1/2 or 2 / DN 40 or 50 95H Series regulators, the spring case vent is tapped so a vent line can be connected to provide venting to a remote location. On NPS 1/4, 1/2, 3/4 and 1 / DN 15, 20 and 25 95H Series body sizes, the tapped vent option is available on request. The exposed end of the vent pipe should be protected with a weather and insect resistant vent assembly.

All vents and remote vent lines should be checked periodically to ensure that they are unobstructed.

Overpressure Protection

The Types 95L, 95H, 95HP and 95HT regulators have an outlet pressure rating lower than the inlet pressure rating. The recommended pressure limitations are stamped on the regulator nameplate. Some type of overpressure protection is needed if the actual inlet pressure exceeds the maximum operating outlet pressure rating. Overpressure protection should also be provided if the regulator inlet pressure is greater than the safe working pressure of downstream equipment.

Some type of external overpressure protection should be provided if inlet pressure will be high enough to damage downstream equipment. Common methods of external overpressure protection include relief valves, monitoring regulators, shutoff devices and series regulation.

Regulator operation below the maximum pressure limitations does not preclude the possibility of damage from external sources or from debris in the pipeline. If the regulator is exposed to an overpressure condition, it should be inspected for any damage that may have occurred.

Startup

The regulator is set at the factory for the setpoint specified on the order, so no initial adjustment should be required to give the desired results. With proper installation completed and relief valves properly adjusted, slowly open the upstream and downstream shutoff valves.

Types 95L, 95H, 95HP and 95HT

Adjustment

The factory setting of the regulator can be varied within the pressure range stamped on the nameplate. To change the outlet pressure, loosen the locknut (key 17, Figure 3, 4 or 5) and turn the adjusting screw (key 15, Figure 3, 4 or 5) clockwise to increase outlet pressure, or counterclockwise to decrease it. Monitor the outlet pressure with a test gauge during the adjustment. Tighten the locknut to maintain the desired setting.

All regulator springs can be backed off to provide zero outlet. Recommended outlet pressure ranges available, maximum inlet pressures and temperatures, and color codes of the respective springs are shown in Tables 1 and 2.

Shutdown

Close the upstream shutoff valve. Close downstream shutoff valve. Open bleed valve between the regulator and the downstream shutoff valve. Without changing regulator spring adjustment, all pressure between the upstream and downstream shutoff valves will be released through the bleed valve, since the Type 95L or 95H regulator opens in response to the decreased outlet pressure.

Maintenance



WARNING

To avoid personal injury, property damage or equipment damage caused by sudden release of pressure or explosion of accumulated gas, do not attempt any maintenance or disassembly without first isolating the regulator from system pressure and relieving all internal pressure from the regulator.

Due to normal wear that may occur, parts must be periodically inspected and replaced if necessary. The frequency of inspection depends on the severity of service conditions. This section includes instructions for disassembly and replacement of parts. All key numbers refer to Figures 3, 4 and 5.

1. Unscrew the valve plug guide (key 5) from the body (key 1). The valve plug spring (key 10) and the valve plug (key 4) will normally come out of the body along with the valve plug guide.

On NPS 1-1/2 or 2 / DN 40 or 50 units the stem (key 6, Figure 5) will also come out of the regulator body.

2. Inspect the seating surface of the valve plug (key 4), make sure that the elastomer, PTFE or polished metal surface of the valve plug is not damaged. Replace if damage is noted.
3. Inspect the seating edge of the orifice (key 3). If damage is noted, unscrew the orifice from the body and replace it with a new part. Torque per Table 3. If no further maintenance is required, reassemble the regulator in the reverse of the above steps. When installing the valve plug guide (key 5) coat the threads and sealing surface with sealant to ensure an adequate metal-to-metal seal. Reassembly torque per Table 3.
4. If diaphragm damage is suspected, or to inspect the diaphragm or other internal parts, loosen the locknut (key 17) and turn the adjusting screw (key 15) to remove all spring compression.

Steps 5 and 6 apply to Type 95L and sizes NPS 1/4 to 1 / DN 25 of the 95H Series. If the unit being disassembled is an NPS 1-1/2 to 2 / DN 40 and 50 size Type 95H, HP or HT, proceed to steps 7 and 8.

5. Remove the diaphragm case cap screws (key 16) and lift off the spring case (key 2). Remove the upper spring seat (key 9) and regulator spring (key 11). On NPS 1/4 to 1 / DN 25 sizes Type 95H units only, remove the lower spring seat (key 8). On Type 95L units, remove the diaphragm head assembly (key 21).
6. Remove the diaphragm(s) and examine for damage. Replace if damage is noted. Note that if the diaphragm is metal, two diaphragms should be used except for Type 95L, NPS 1/4 with 2 to 6 psi / 0.14 to 0.41 bar spring range which uses only one metal diaphragm.
7. Remove the diaphragm-diaphragm head assembly. It can be disassembled for inspection of the diaphragm (key 12) and two small diaphragm gaskets (key 47) or O-ring (key 45). Remove the locknut (key 31) from the pusher post (key 30) and separate the assembly. An O-ring is used to seal around the pusher post if an elastomer diaphragm is used, and the gaskets are used with stainless steel diaphragm(s).
8. Unscrew and remove the stem guide bushing (key 7). An O-ring (key 51) held in place by the packing follower (key 50) can then be examined for damage.

9. With diaphragm(s) removed, check to be sure the pressure registration hole (pitot tube, key 20, in NPS 3/4 / DN 20 and larger sizes) is completely open and free of all obstructions.
10. If the unit has metal diaphragms,
 - a. (Applicable only for the lower diaphragm head of Type 95H/HT, NPS 1-1/2 to 2)

Find the pusher post (key 30) and place on a surface with the larger flat surface down and the thread stem up (metal diaphragm pusher post has a recessed diameter in the bottom surface). Then, find one smaller elastomer (or graphite) gaskets (key 47) and fit it over the threaded end of the pusher post. Find and take one of the diaphragm heads and slip it over the threaded end of the pusher post with the chamfered side of the diaphragm head toward the gasket. Take a second gasket and place it over the threaded end of the pusher post on top of the diaphragm head.
 - b. Replace the large diaphragm gasket (key 19) on the surface of the body that will support the diaphragms. There will be two diaphragms used per regulator, except for 95L, NPS 1/4 with 2 to 6 psi / 0.14 to 0.41 bar outlet setting which uses only one metal diaphragm. The raised surfaces of the metal diaphragms should be placed in the unit so that they are facing toward the assembler (toward the spring) except only when one diaphragm is being used then the raised surface should be facing down (towards the body). See Figures 2 and 4 as references.

11. Reassemble in the reverse of the above procedures. Lubricate the upper spring seat and the exposed threads of the adjusting screw with Anti-Seize lubricant.

Before tightening cap screws (key 16) be sure to install the adjusting screw, if completely removed, and turn it down so that diaphragm slack is obtained. This allows proper positioning of the diaphragm to permit full travel of the valve plug. Torque diaphragm cap screws per Table 3. Complete reassembly procedures and turn the adjusting screw to produce the desired outlet pressure. Tighten the locknut to maintain the desired setting.

Parts Ordering

When corresponding with your local Sales Office about this equipment, always reference the equipment serial number or FS number that can be found on the nameplate.

When ordering replacement parts, reference the key number of each needed part as found in the following parts list. Separate kits containing all recommended spare parts are available.

Parts List

Note

In this parts list, parts marked NACE are intended for corrosion-resistant service as detailed in the NACE International Standard MR0175.

Key	Description	Part Number
	Parts Kit (Included are keys 3, 4, 10, 12 and 19 (for All Metal Trim only))	
	Types 95H and 95HP	
	For Brass and Neoprene (CR) Trim,	
	NPS 1/2 / DN 15 body	R95HX000022
	NPS 3/4 and 1 / DN 20 and 25 bodies	R95HX000032
	For 416 Stainless steel and Neoprene (CR) Trim,	
	NPS 1/2 / DN 15 body	R95HX000112
	NPS 3/4 and 1 / DN 20 and 25 bodies	R95HX000122
	NPS 1-1/2 and 2 / DN 40 and 50 bodies	R95HX000042
	For All Metal Trim,	
	NPS 1/2 / DN 15 body	R95HX000062
	NPS 3/4 and 1 / DN 20 and 25 bodies	R95HX000072
	NPS 1-1/2 and 2 / DN 40 and 50 bodies	R95HX000082
	Extra parts for NPS 1-1/2 and 2 / DN 40 and 50 bodies	
	include keys 47, 51 and 52	
	Type 95L	
	For Brass and Neoprene (CR) Trim,	
	NPS 1/2 / DN 15 body	R95LX000022
	NPS 3/4 and 1 / DN 20 and 25 bodies	R95LX000032
	For 416 Stainless steel and Neoprene (CR) Trim,	
	NPS 1/2 / DN 15 body	R95LX000112
	NPS 3/4 and 1 / DN 20 and 25 bodies	R95LX000122
	For All Metal Trim, Trim 1 or 4A	
	NPS 1/2 / DN 15 body	R95LX000052
	NPS 3/4 and 1 / DN 20 and 25 bodies	R95LX000062
1	Regulator Body	
2	Spring Case	
3*	Orifice	
	Metal Seat (Types 95L, 95H and 95HT)	
	416 Stainless steel	
	NPS 1/2 / DN 15 body	1E395046172
	NPS 3/4 and 1 / DN 20 and 25 bodies	1E398046172
	NPS 1-1/2 and 2 / DN 40 and 50 bodies	2P787046172
	316 Stainless steel	
	NPS 1/2 / DN 15 body	1E395035072
	NPS 3/4 and 1 / DN 20 and 25 bodies	1E398035072
	NPS 1-1/2 and 2 / DN 40 and 50 bodies	2P787035072
	Brass	
	NPS 1-1/2 and 2	2P787046172

Types 95L, 95H, 95HP and 95HT

Key 4, Valve Plug Part Numbers

VALVE PLUG MATERIAL	1/2 / 15	3/4 and 1 / 20 and 25	1-1/2 and 2 / 40 and 50
	Metal Seat (Types 95L, 95H and 95HT)		
416 SST 316 SST	1E395146172 1E395135072	1E398146172 1E398135072	1U403746172 1U4037X0012
Elastomer Seat (Types 95L, 95H and 95HP)			
Brass/Neoprene (CR) 416 SST/Neoprene (CR) 316 SST/Neoprene (CR) (NACE) 416 SST/Nitrile (NBR) 316 SST/FKM (NACE)	1E3963000A2 1E3963000B2 1E3963X0012 ----- -----	1E3996000A2 1E3996000B2 1E3996X0012 ----- 1E3996X0082	1U4039X0052 ----- 1U4039X0082 1U4039000A2 1U4039X0102

Key	Description	Part Number	Key	Description	Part Number
3	Orifice (continued)		19*	Diaphragm Gasket, Types 95L and 95H use composition, Type 95HT uses graphite (Use with metal diaphragm)	
	Elastomer Seat (Types 95L, 95H and 95HP)			(Use with metal diaphragm)	
	Brass (Types 95L and 95H only)			NPS 1/2 / DN 15 body	
	NPS 1/2 / DN 15 body	1E396214012		Type 95L	1E397004022
	NPS 3/4 and 1 / DN 20 and 25 bodies	1E399514012		Type 95H	ERCA00485A0
	NPS 1-1/2 and 2 / DN 40 and 50 bodies	1P7860X0092		NPS 3/4 and 1 / DN 20 and 25 bodies	
	416 Stainless steel			Type 95L	ERCA00556A0
	NPS 1/2 / DN 15 body	1E396235132		Type 95H	ERCA00510A0
	NPS 3/4 and 1 / 20 and 25 bodies	1E399535132		NPS 1-1/2 and 2 / DN 40 and 50 bodies	
	NPS 1-1/2 and 2 / DN 40 and 50 bodies	1P786035132		Type 95H	ERCA00526A0
	316 Stainless steel, NACE		20	Pitot Tube	
	NPS 1/2 / DN 15 body	1E396235072	21	Diaphragm Head Assembly, Type 95L only	
	NPS 3/4 and 1 / DN 20 and 25 bodies	1E399535072		Aluminum and Stainless steel	
	NPS 1-1/2 and 2 / DN 40 and 50 bodies	1P7860X00A2	22	Adjusting Screw Assembly	
4*	Valve Plug	See Following Table	23	Handwheel, Zinc (NPS 1/2 / DN 15 body)	
5	Valve Plug Guide		24	Machine Screw, Steel (handwheel construction)	
6	Stem Assembly		25	Lockwasher, Steel (handwheel construction)	
6	Stem			The following parts are for the NPS 1-1/2 and 2 / DN 40 and 50 Types 95H, 95HP and 95HT only	
7	Stem Guide Bushing		30	Pusher Post, Stainless steel	
	NPS 3/4 and 1 / DN 20 and 25 bodies	1E398535072	31	Locknut, Steel	
	NPS 1-1/2 and 2 / DN 40 and 50 bodies	1P7854X00A2	45*	O-ring, Nitrile (NBR)	
8	Lower Spring Seat			(Use with Neoprene (CR) diaphragm)	1C782206992
9	Upper Spring Seat, Steel			(Use with Fluorocarbon (FKM) diaphragm)	1K756106382
10	Valve Plug Spring		47*	Diaphragm Gasket	
	Stainless steel			Use with metal diaphragm (2 required)	
	NPS 1/2 / DN 15 body	1E395537022		Type 95H (NPS 1-1/2 to 2 / DN 40 to 50 only), Composition	ERCA00579A0
	NPS 3/4 and 1 / DN 20 and 25 bodies	1E398837022	48	Diaphragm Head (2 required)	
	NPS 1-1/2 and 2 / DN 40 and 50 bodies	1P785837012	49	Lockwasher, Steel	
11	Regulator Spring		50	Packing Follower	
12*	Diaphragm	See Following Table	51*	O-ring, PTFE	1P785906242
14	Diaphragm Protector, PTFE		52	Spring, Stainless steel	1P785737012
15	Adjusting Screw, Steel		54	Inner Valve Base	
16	Cap Screw, Steel		56	NACE Tag	-----
17	Locknut, Steel		57	Tag Wire	-----
18	Drive Screw, Stainless steel (2 required)				

*Recommended spare parts

Types 95L, 95H, 95HP and 95HT

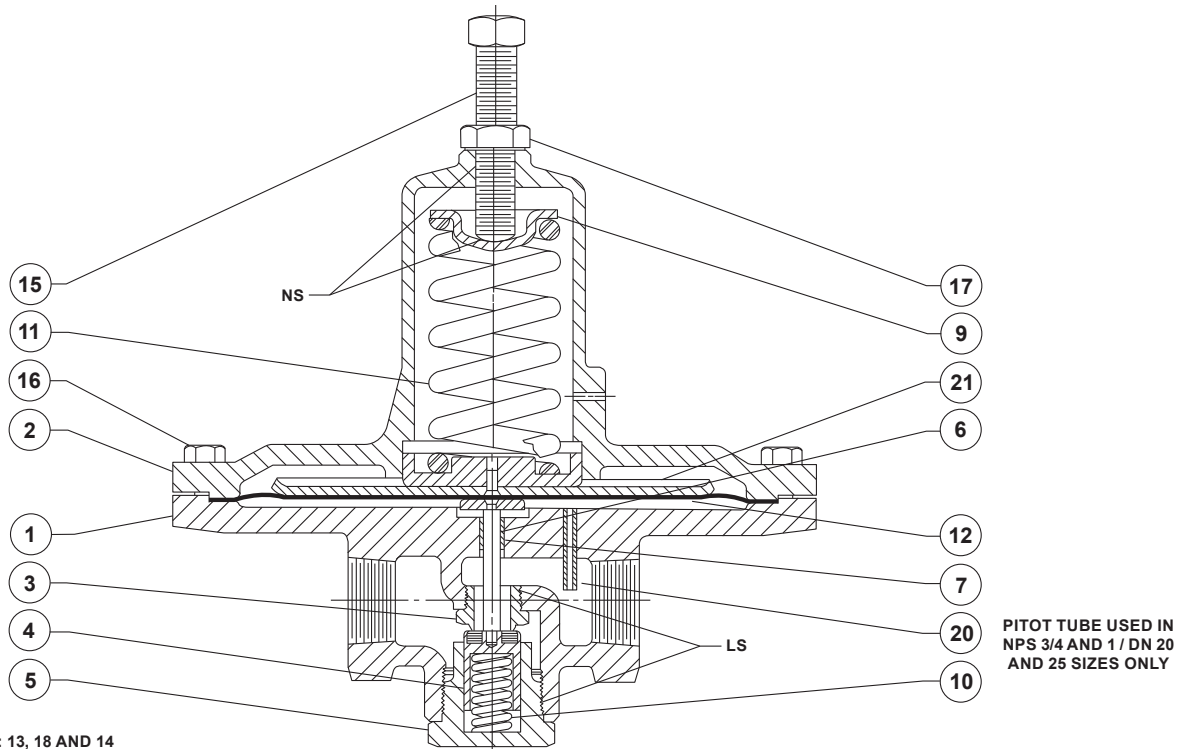

30A6997

PARTS NOT SHOWN: 13, 18 AND 14

NS - NEVER-SEEZ®
LS - LEAD SEAL

Figure 3. Type 95L with Elastomer Seat, NPS 1/4 to 1 / DN 25 Sizes Assembly

Key 12, Diaphragm Part Numbers

BODY SIZE, NPS / DN	DIAPHRAGM MATERIAL	
	302 Stainless Steel (2 Required)	Neoprene (CR)
TYPE 95L		
1/2 / 15 3/4 and 1 / 20 and 25	ERCA00490A0 ERCA00557A0	ERCA00509A0 ERCA00599A0
TYPE 95H		
1/2 / 15 3/4 and 1 / 20 and 25 1-1/2 and 2 / 40 and 50	ERCA00459A0 ERCA00511A0 ERCA00527A0	ERCA00507A0 ERCA00515A0 ERCA00661A0
TYPE 95HP		
1/2 / 15 3/4 and 1 / 20 and 25 1-1/2 and 2 / 40 and 50	----- ----- -----	ERCA00507A0 ERCA00515A0 ERCA00661A0

Types 95L, 95H, 95HP and 95HT

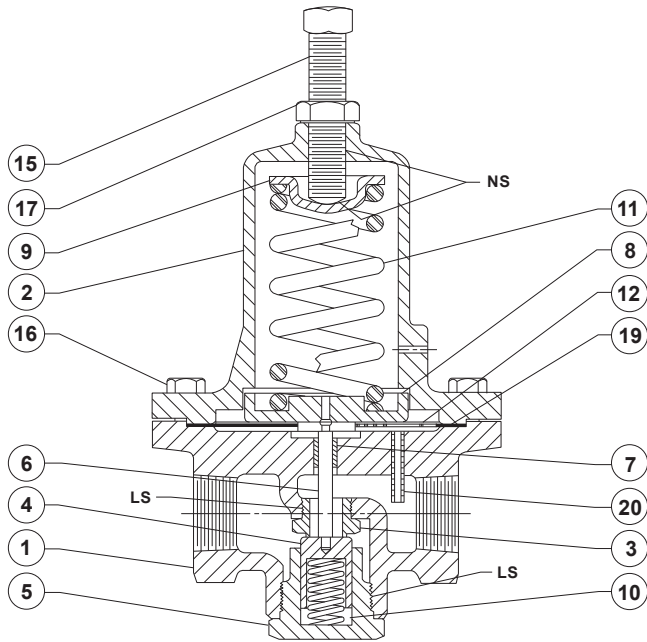

30A7000

TYPE 95H

PITOT TUBE USED IN
NPS 3/4 AND 1 / DN 20 AND 25
SIZES ONLY

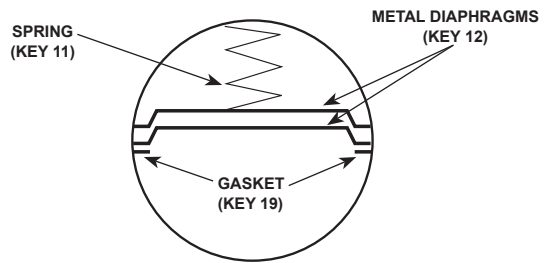

TYPE 95H WITH 2 METAL DIAPHRAGMS

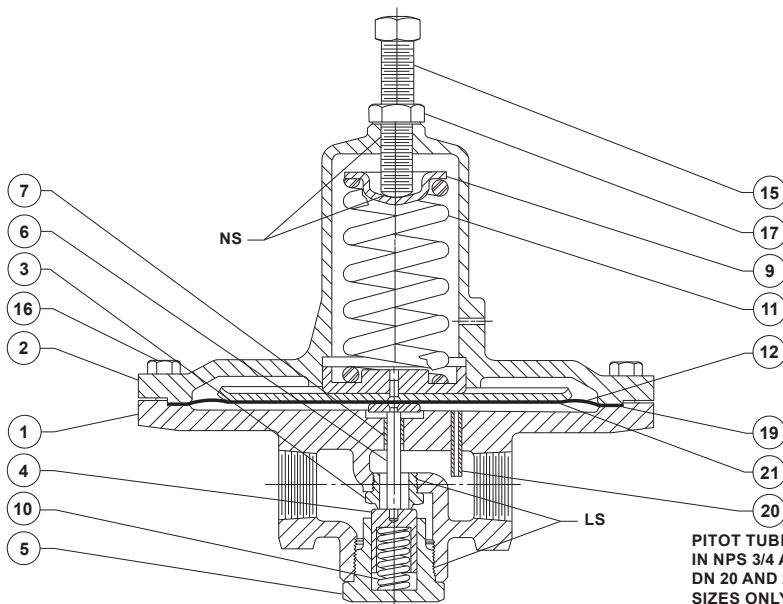

30A6996_B

PARTS NOT SHOWN:
13, 18 AND 14

TYPE 95L

PITOT TUBE USED IN
NPS 3/4 AND 1 / DN 20 AND 25
SIZES ONLY

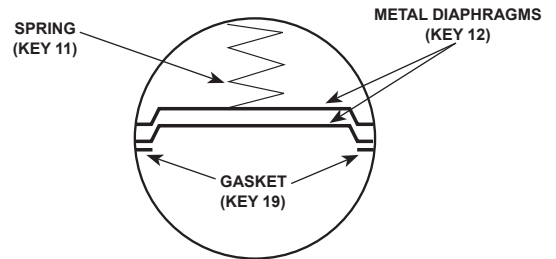

**TYPE 95L WITH 2 METAL DIAPHRAGMS
(EXCEPT ONLY TYPE 95L,
NPS 1/4, 2 TO 6 psi / 0.14 to 0.41 bar RANGE)**

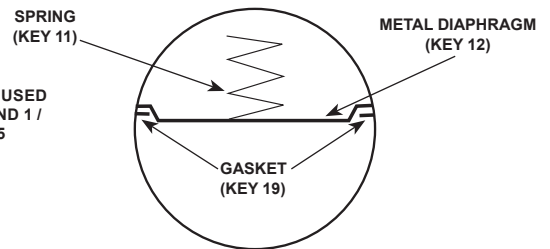

**TYPE 95L (NPS 1/4, 2 TO 6 psi / 0.14 to 0.41 bar RANGE)
WITH METAL DIAPHRAGM**

NS - NEVER-SEEZ®
LS - LEAD SEAL

Figure 4. 95 Series with Metal Seat Assemblies

Never-Seez® is a mark owned by Bostik Corp.

Types 95L, 95H, 95HP and 95HT

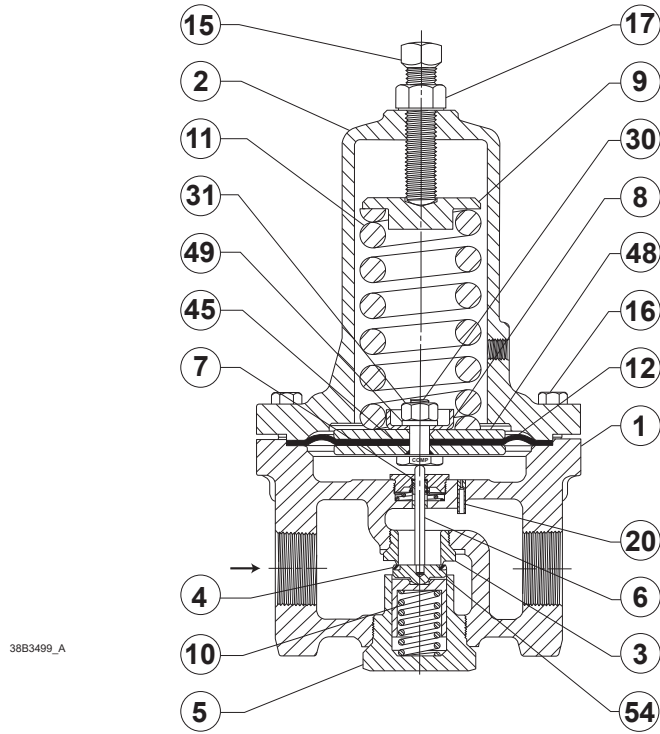

ELASTOMER SEAT

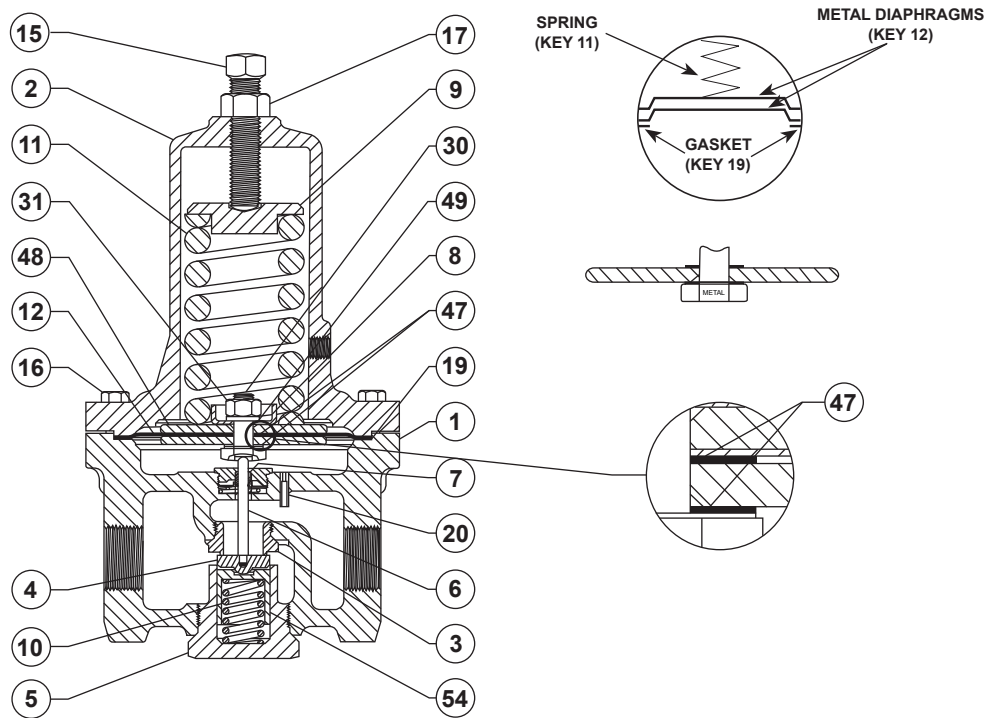

METAL SEAT

Figure 5. 95H Series, NPS 1-1/2 and 2 / DN 40 and 50 Sizes Assemblies (Also Typical of 95HT)

Types 95L, 95H, 95HP and 95HT

✉ Webadmin.Regulators@emerson.com

🔍 Fisher.com

📘 Facebook.com/EmersonAutomationSolutions

🌐 LinkedIn.com/company/emerson-automation-solutions

🐦 Twitter.com/emr_automation

Emerson Automation Solutions

Americas

McKinney, Texas 75070 USA
T +1 800 558 5853
+1 972 548 3574

Europe

Bologna 40013, Italy
T +39 051 419 0611

Asia Pacific

Singapore 128461, Singapore
T +65 6777 8211

Middle East and Africa

Dubai, United Arab Emirates
T +971 4 811 8100

D100256X012 © 1954, 2020 Emerson Process Management Regulator Technologies, Inc. All rights reserved. 09/20.

The Emerson logo is a trademark and service mark of Emerson Electric Co. All other marks are the property of their prospective owners. Fisher™ is a mark owned by Fisher Controls International LLC, a business of Emerson Automation Solutions.

The contents of this publication are presented for informational purposes only, and while every effort has been made to ensure their accuracy, they are not to be construed as warranties or guarantees, express or implied, regarding the products or services described herein or their use or applicability. All sales are governed by our terms and conditions, which are available upon request. We reserve the right to modify or improve the designs or specifications of such products at any time without notice.

Emerson Process Management Regulator Technologies, Inc. does not assume responsibility for the selection, use or maintenance of any product. Responsibility for proper selection, use and maintenance of any Emerson Process Management Regulator Technologies, Inc. product remains solely with the purchaser.

